

DEMONIO

© Fernando Gilgado Gómez (Spain) 2002

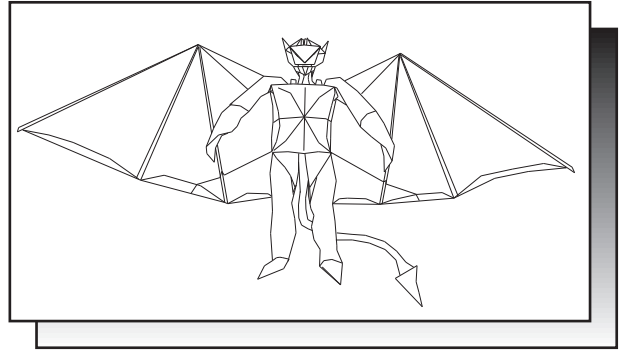

Color abajo

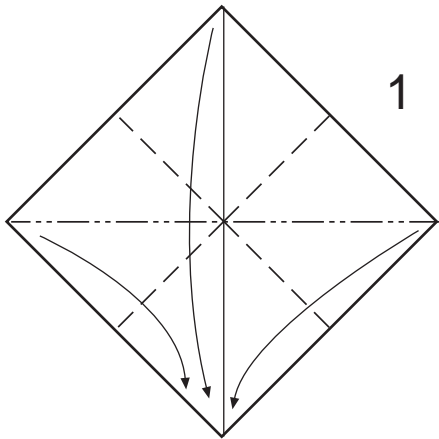

1

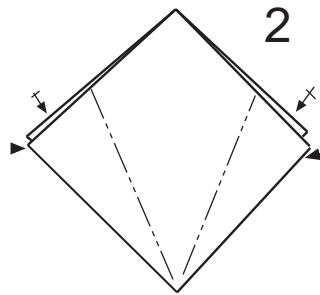

2

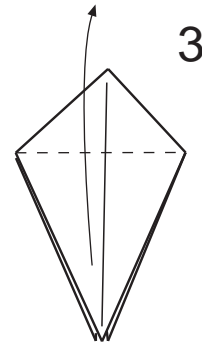

3

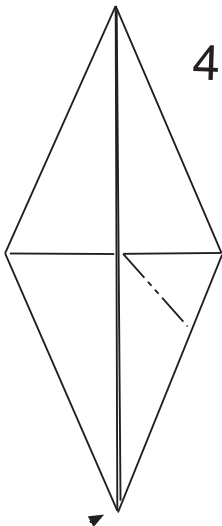

4

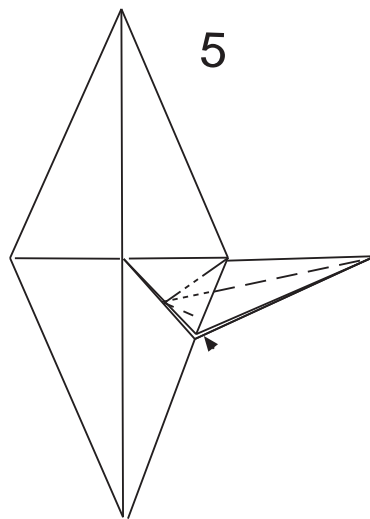

5

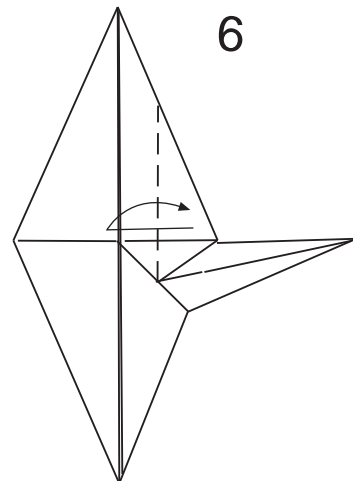

6

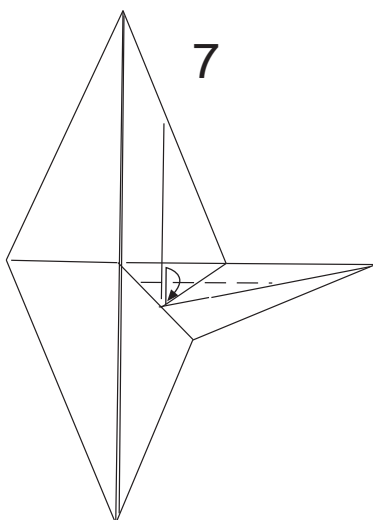

7

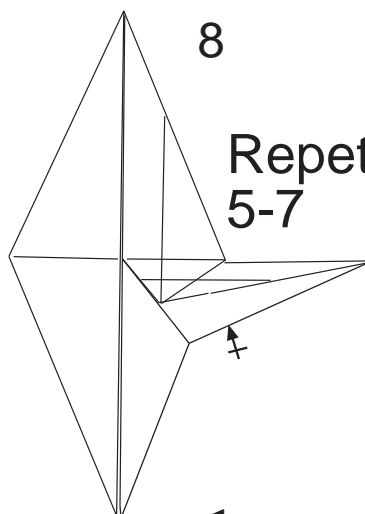

8

Repetir
5-7

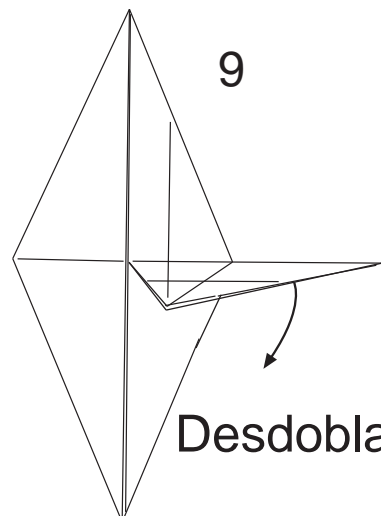

9

Desdoblar

1

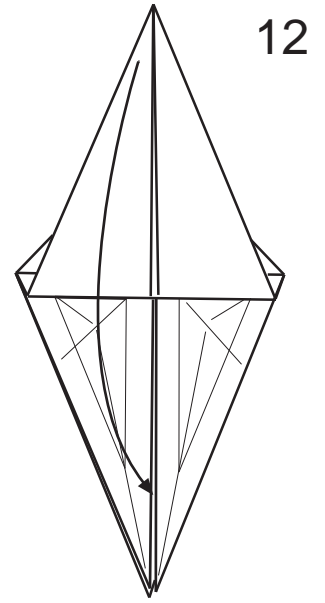
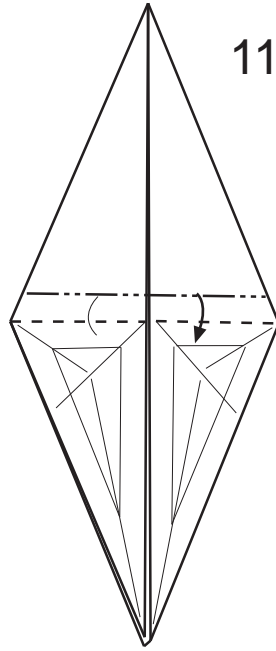
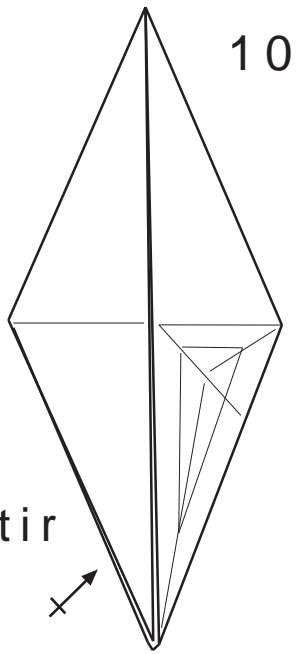

Repetir
4-9

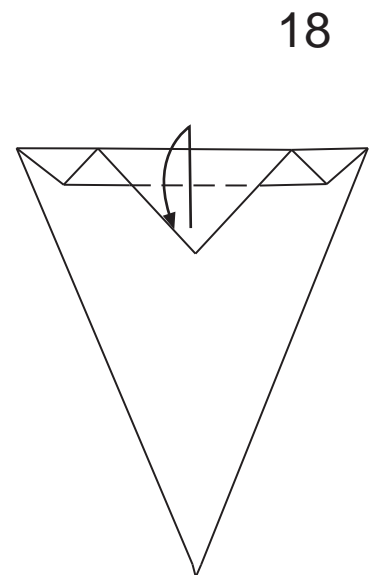
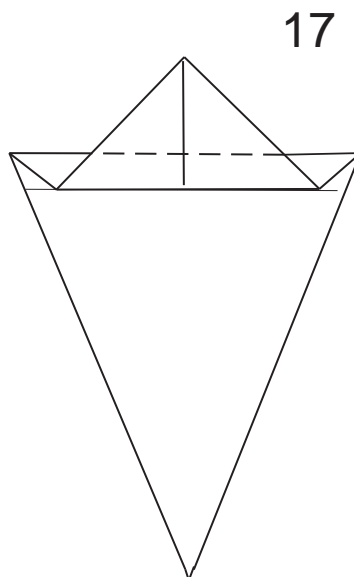
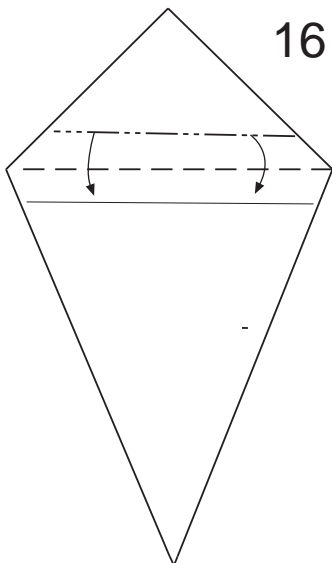
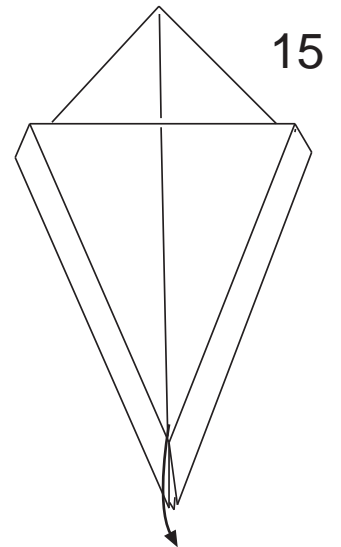
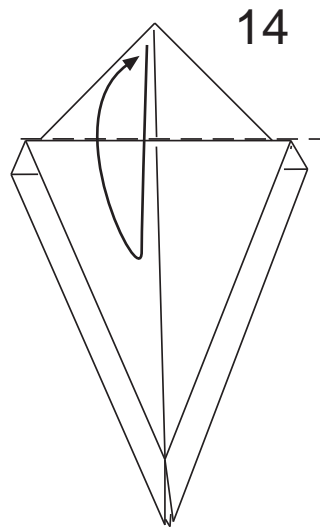
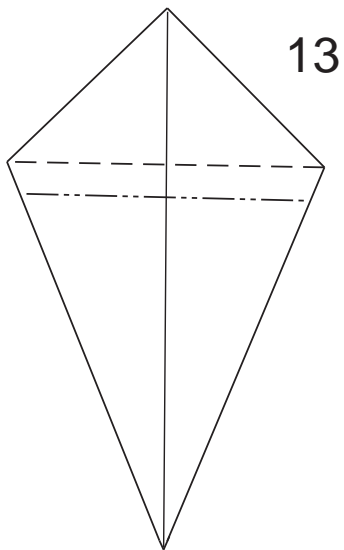

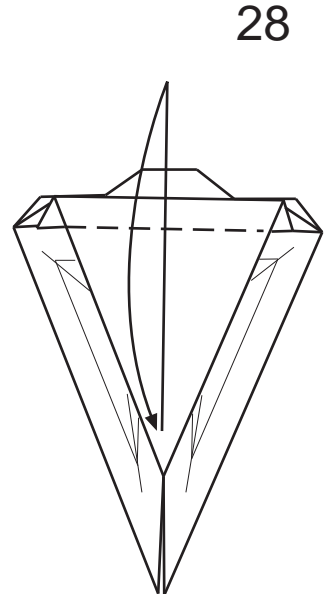
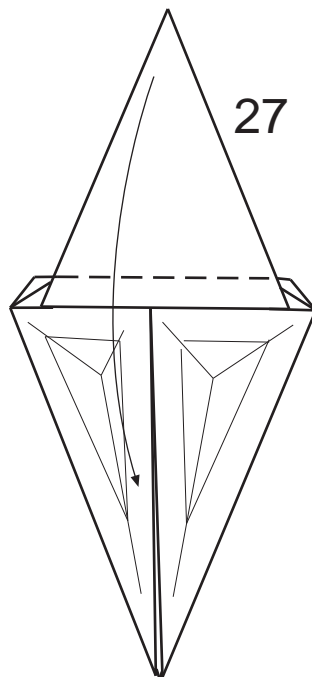
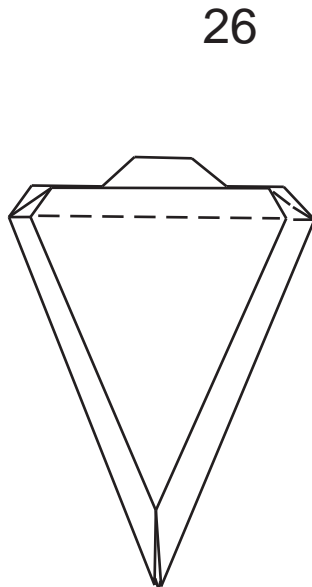
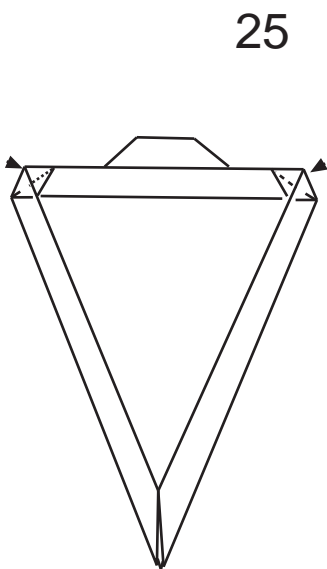
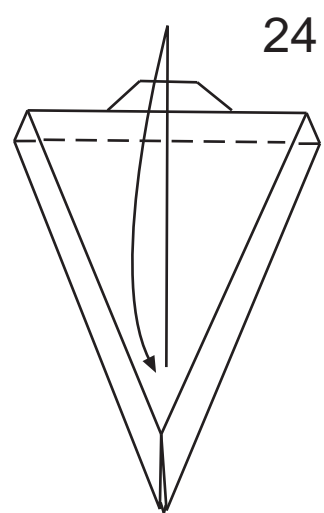
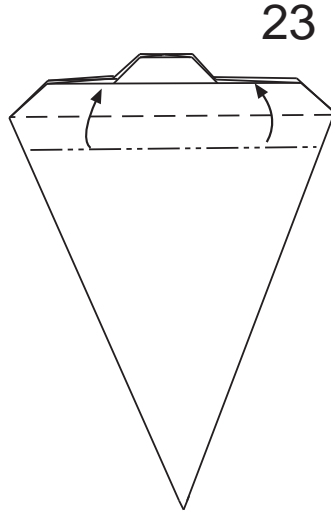
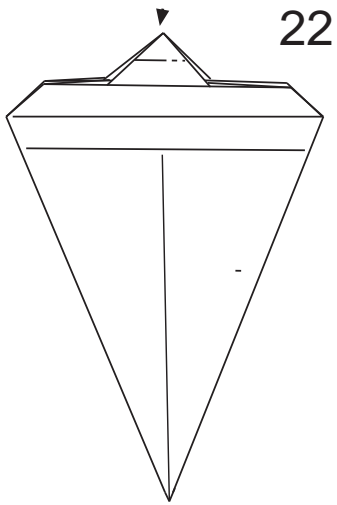
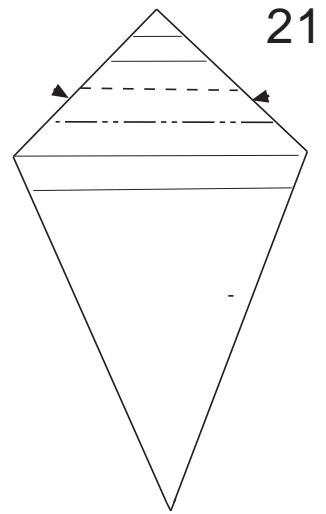
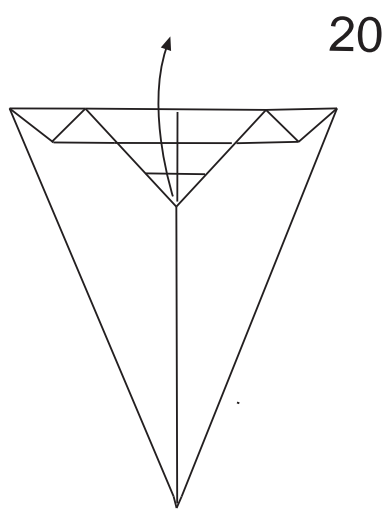
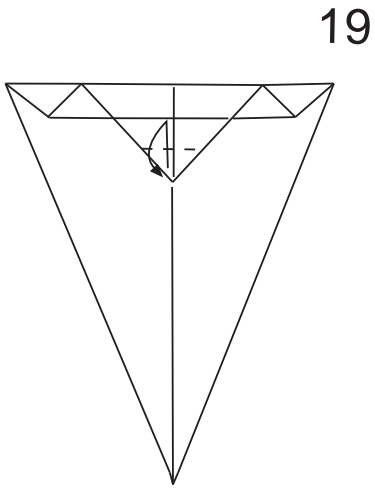

Hundir 29

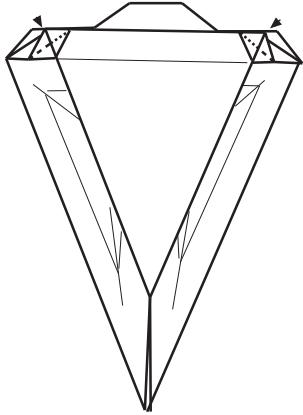

Estirar 30

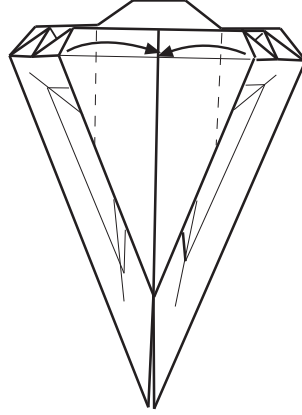

Dar la vuelta 31

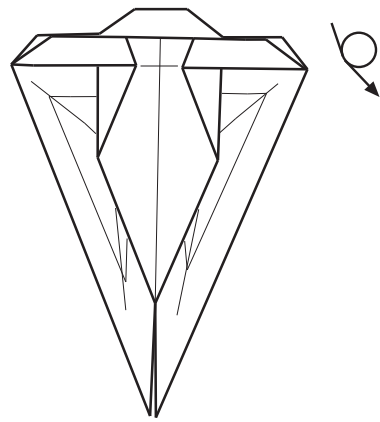

Repetir 23-31 32

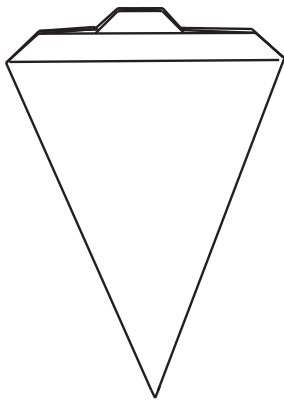

Una solapa a la izquierda y otra a la derecha 33

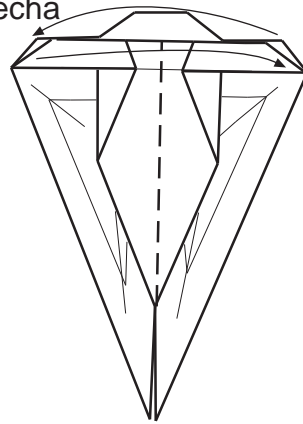

34 Girar

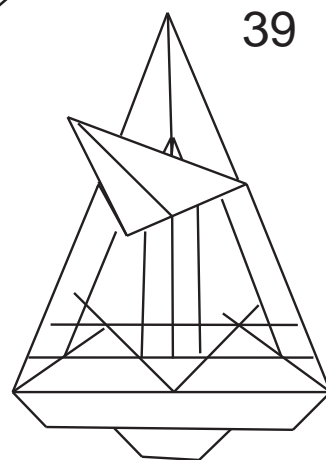
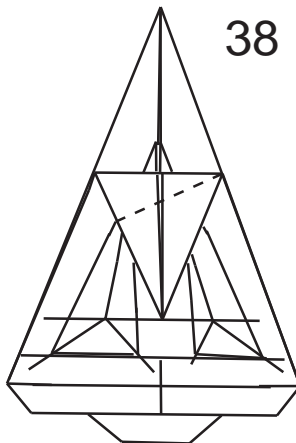
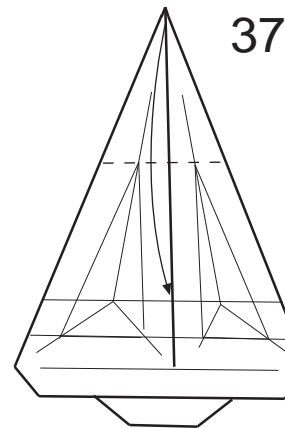
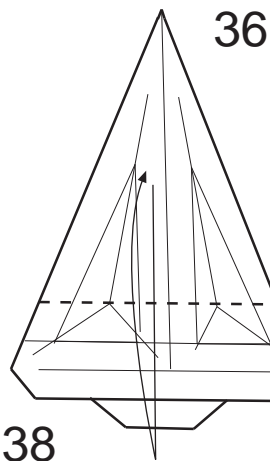
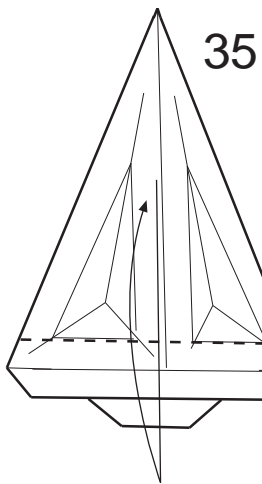
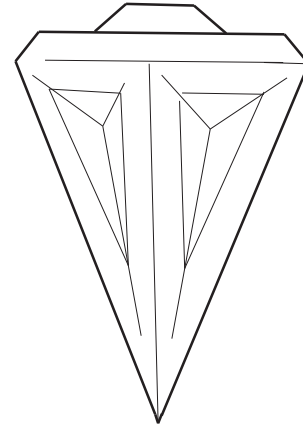

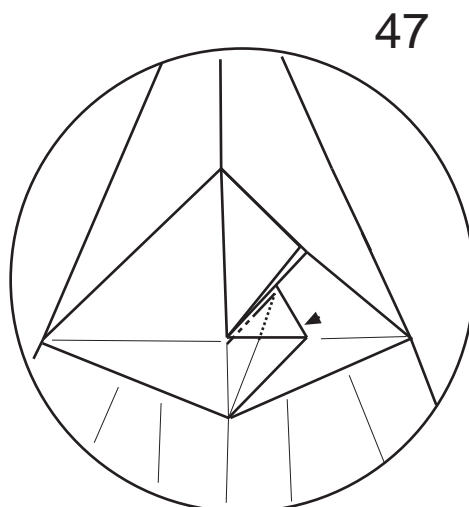
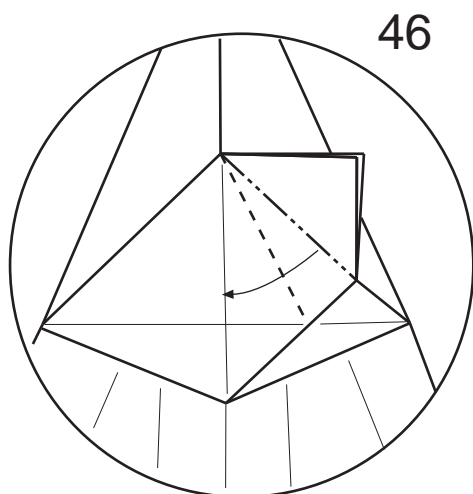
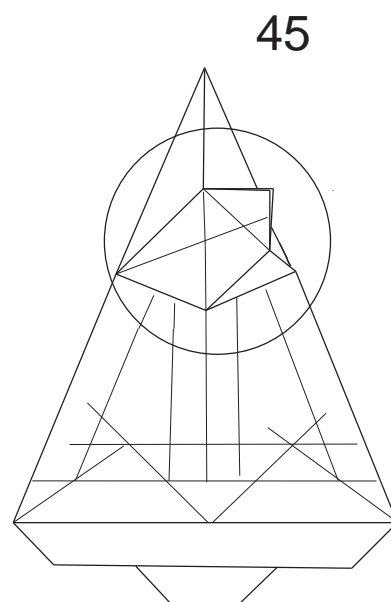
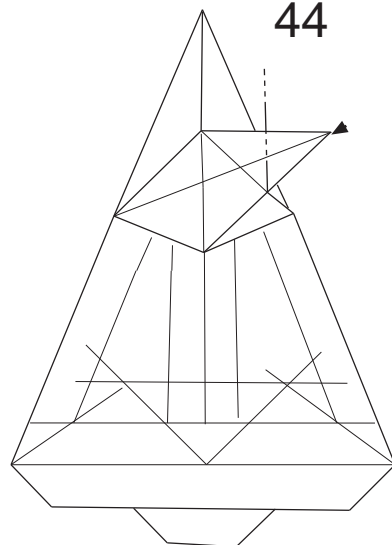
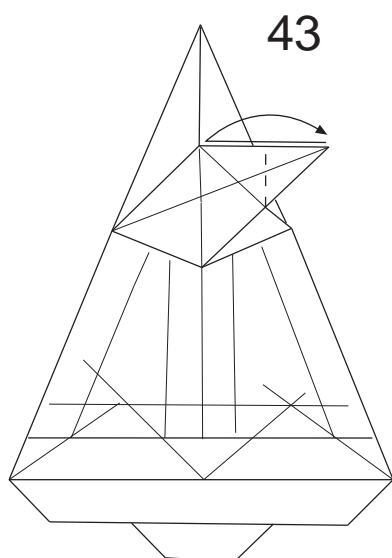
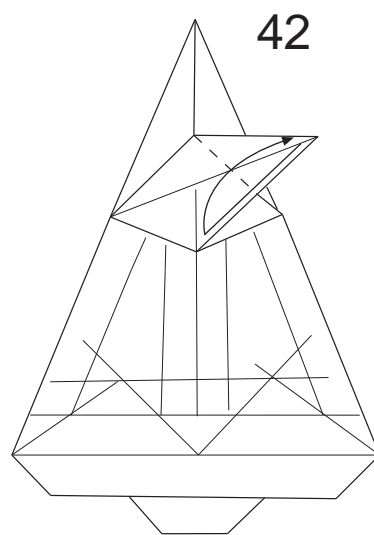
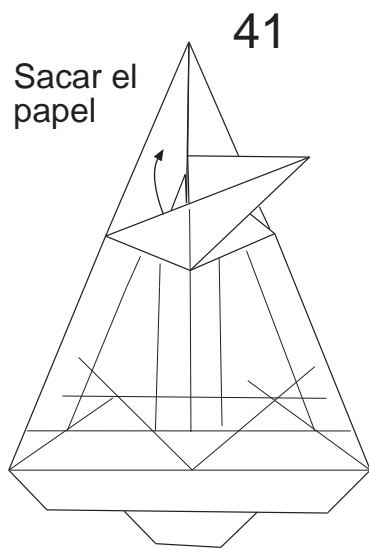
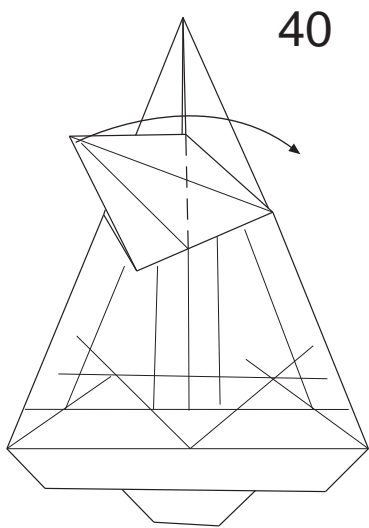

48

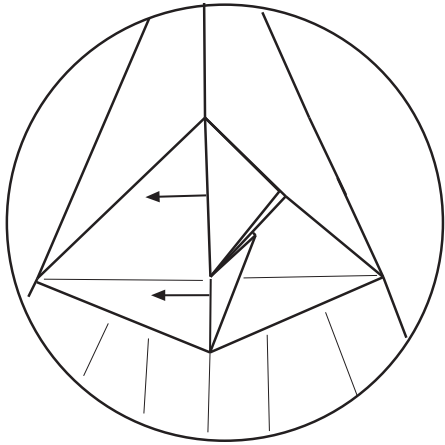

Sacar el papel

49

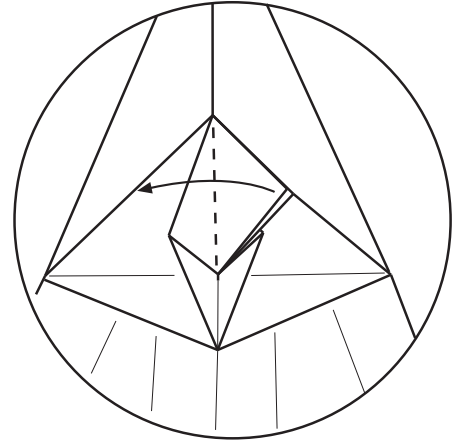

50

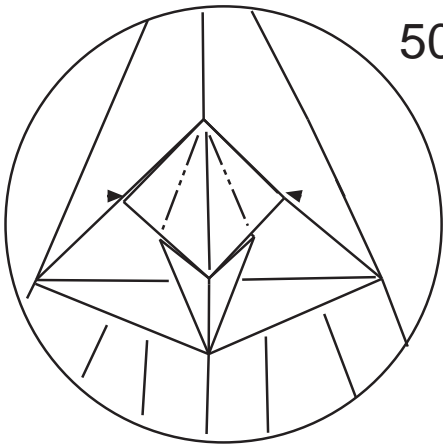

51

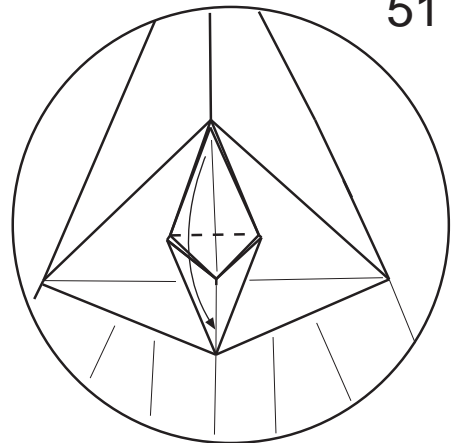

52

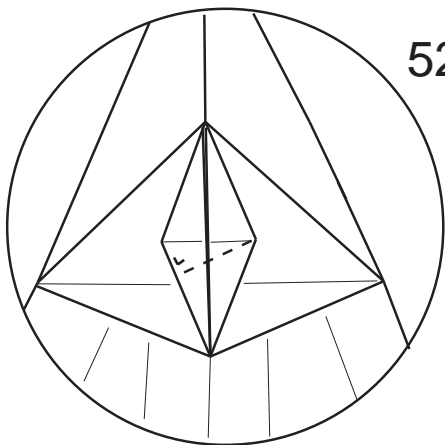

53

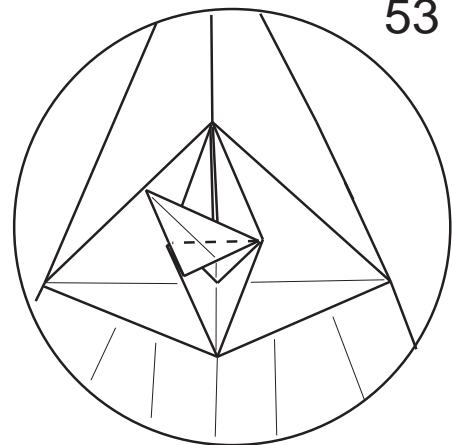

54

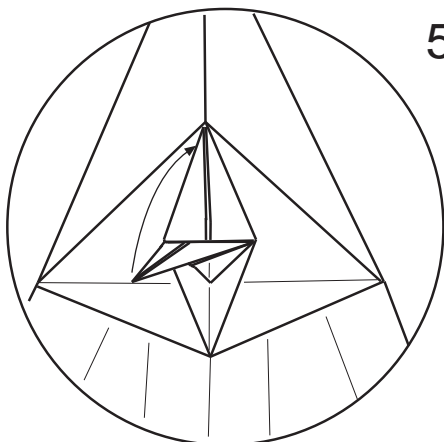

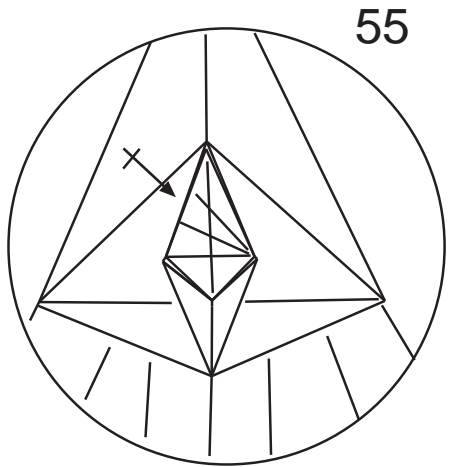

55

Repetir
51-54
simetricamente

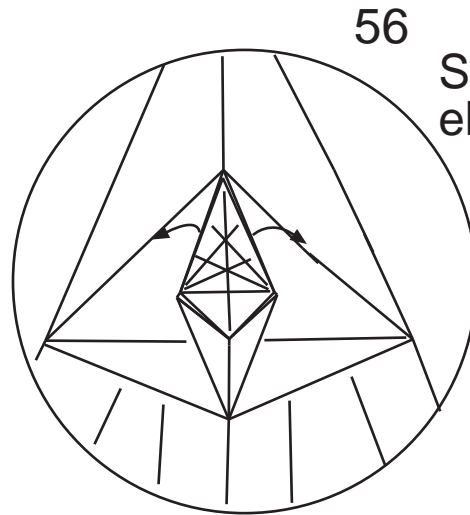

56

Sacar
el papel

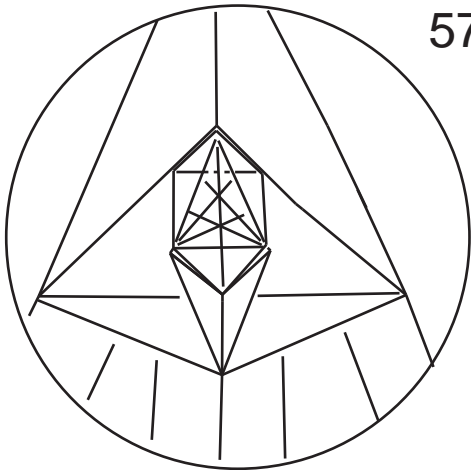

57

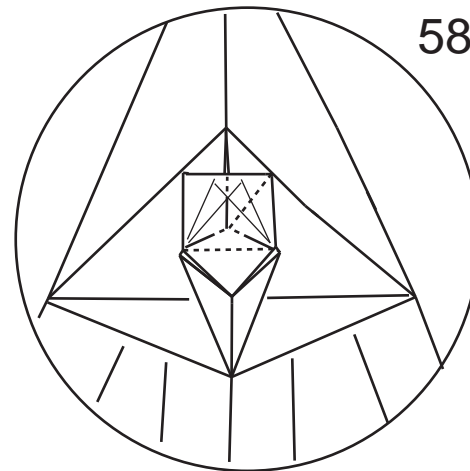

58

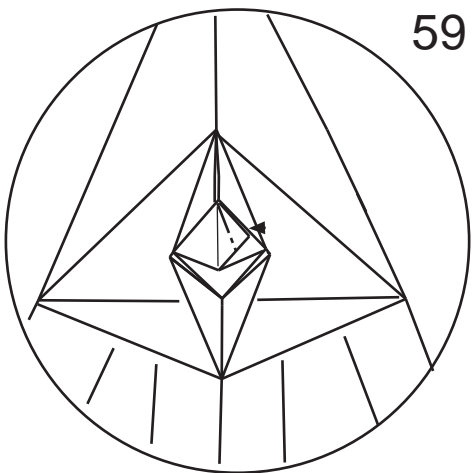

59

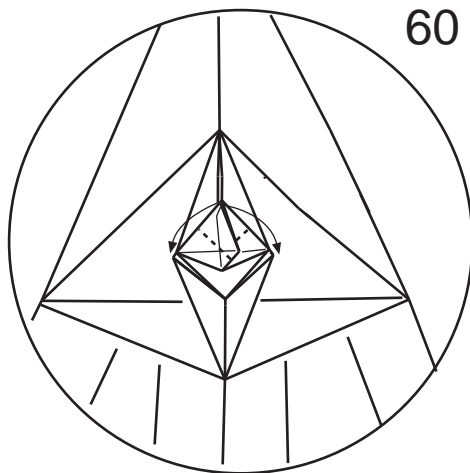

60

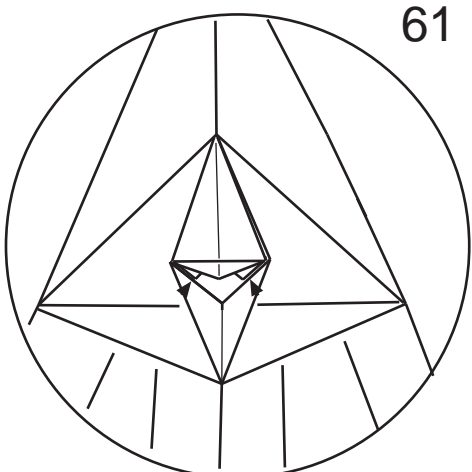

61

62

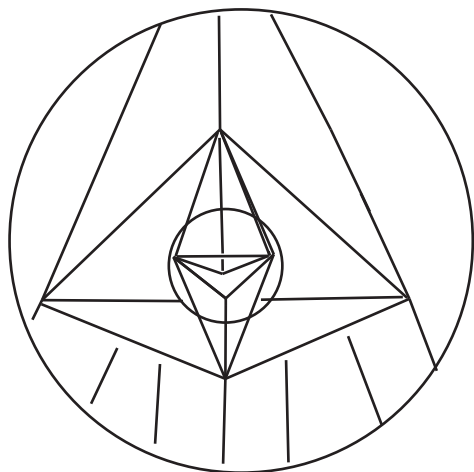

63

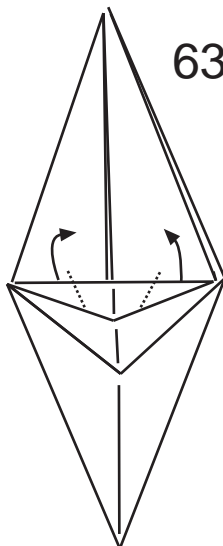

64

Introducir "B" dentro de "A"

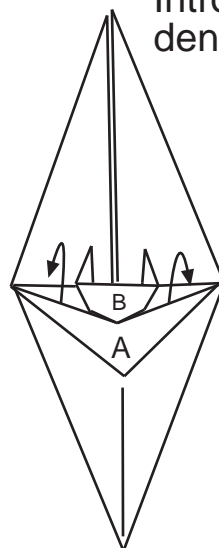

65

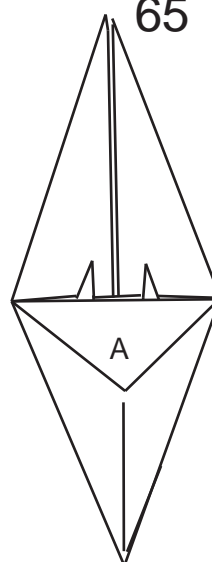

66

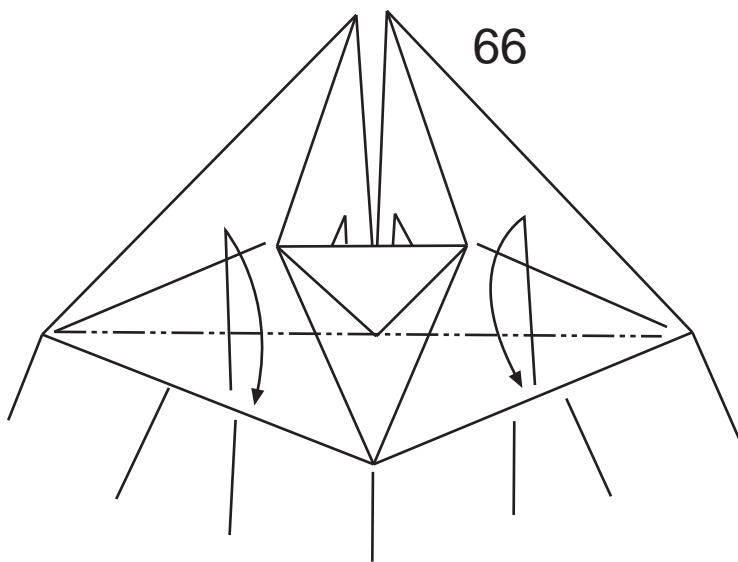

67

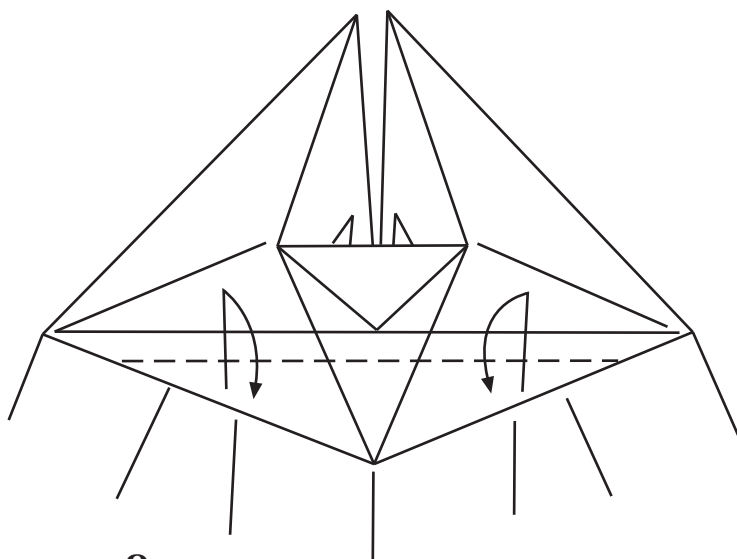

8

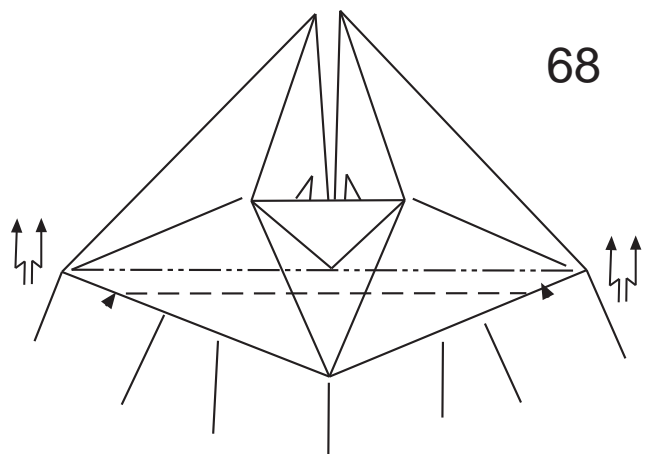

68

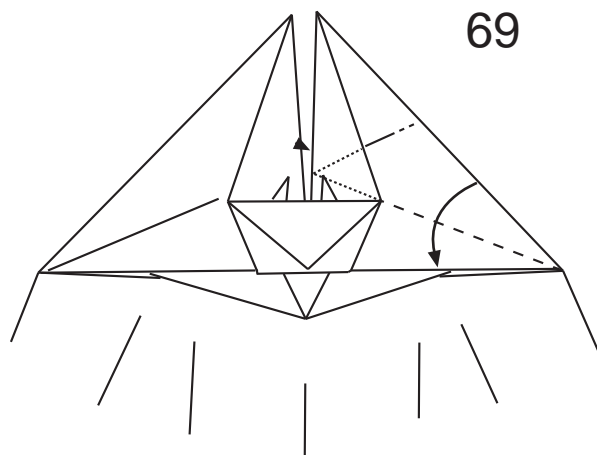

69

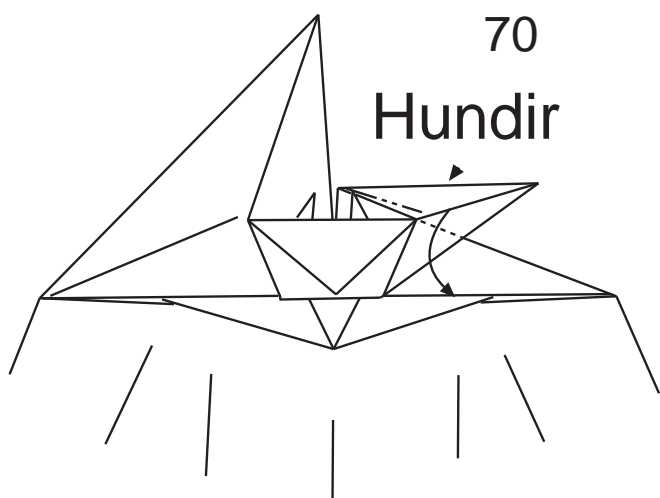

70

Hundir

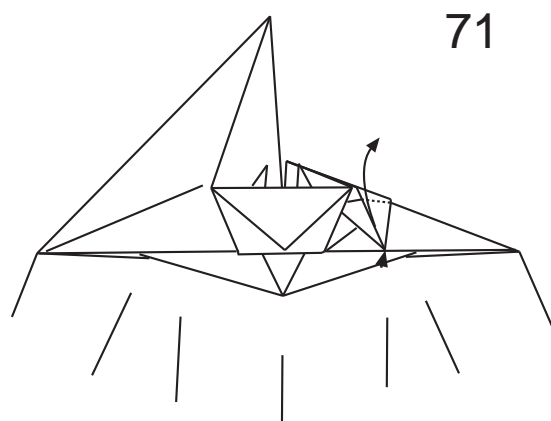

71

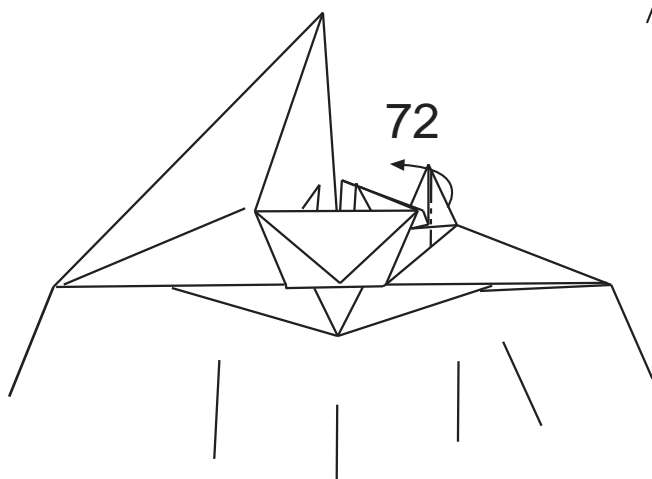

72

73

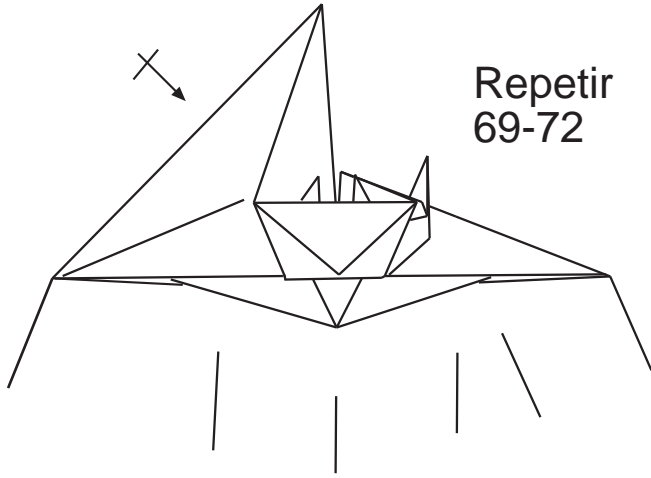

Repetir
69-72

74

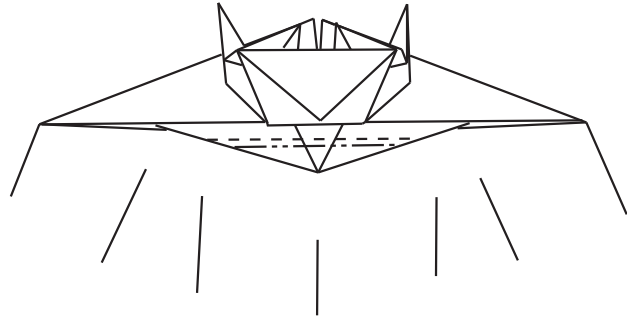

75

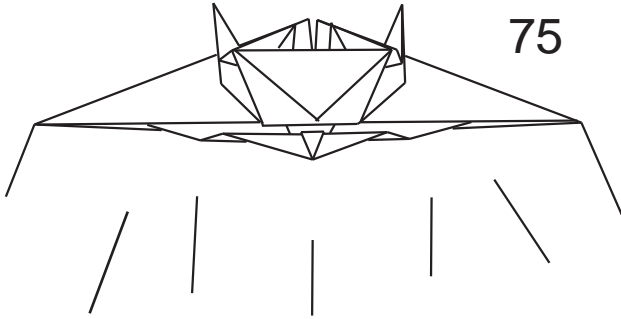

76

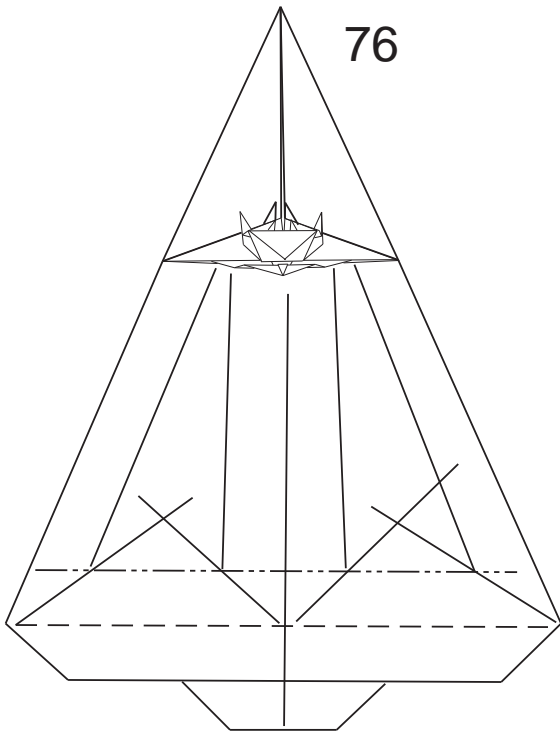

77

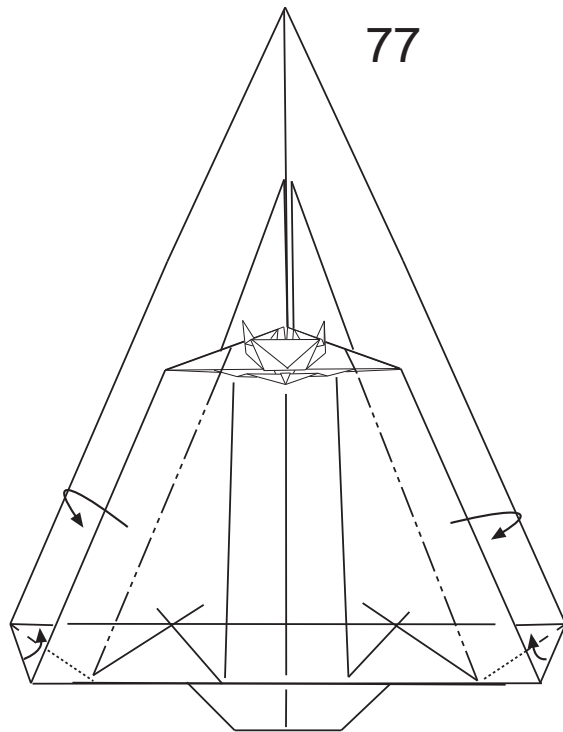

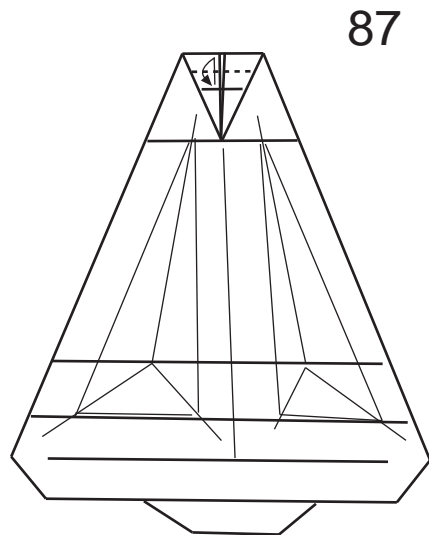
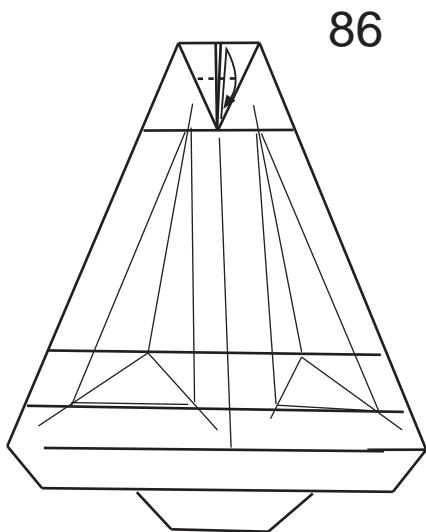
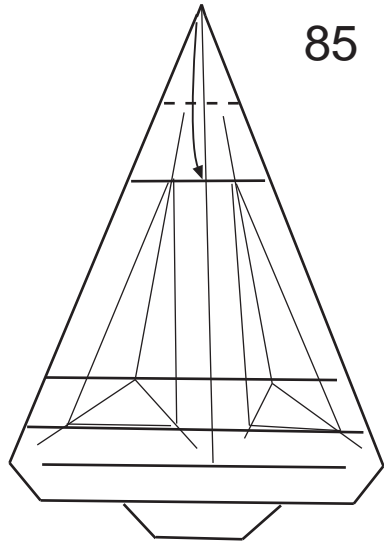
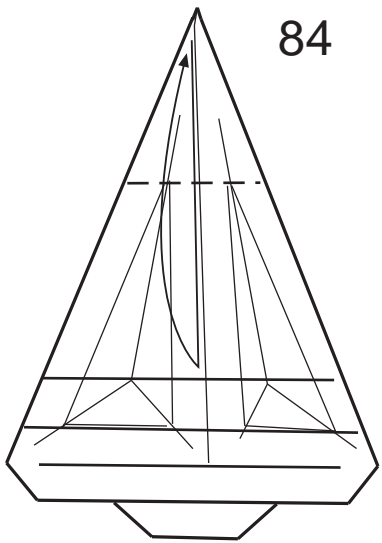
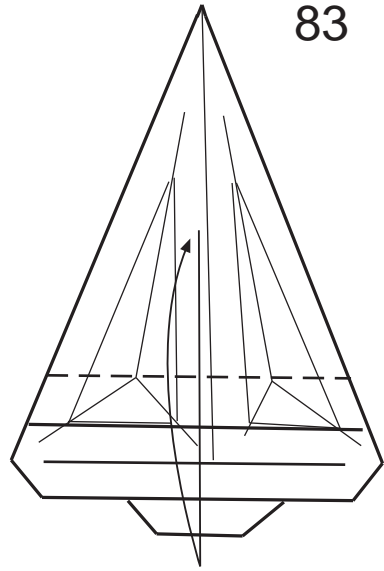
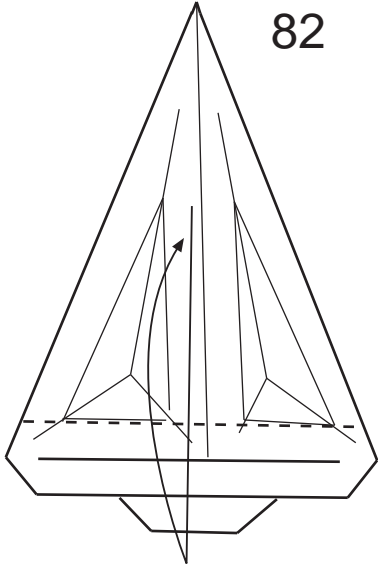

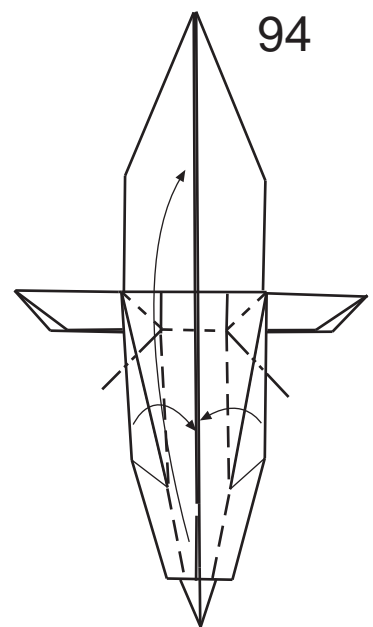
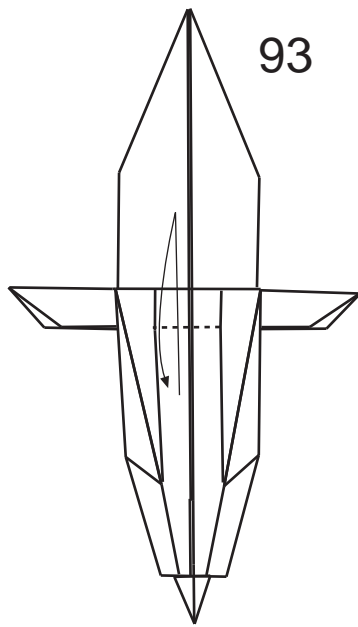
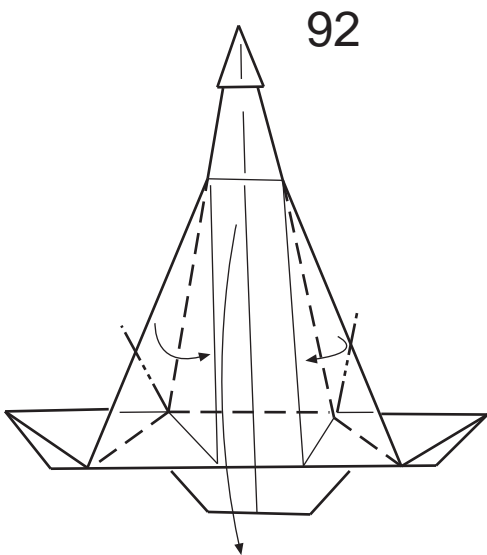
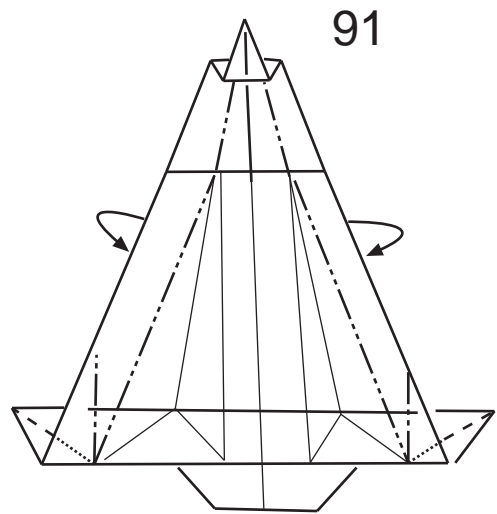
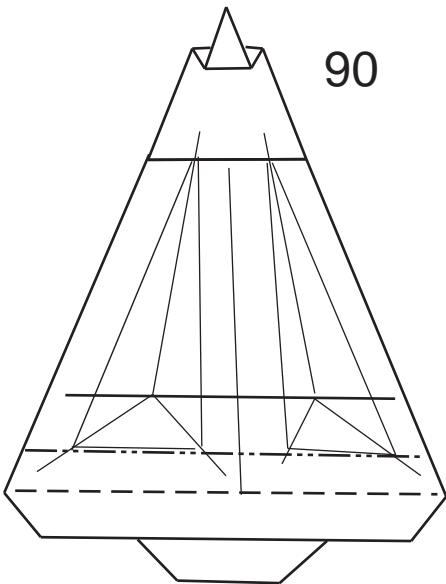
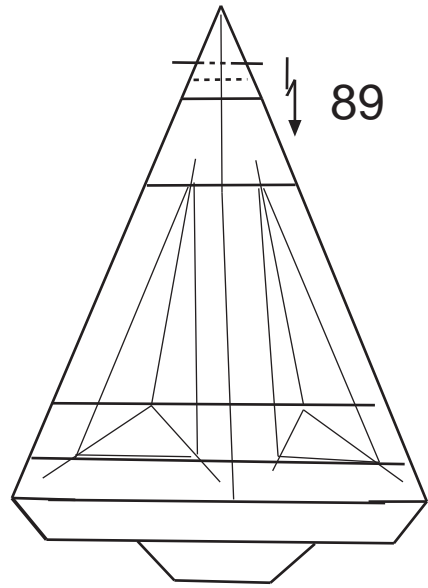
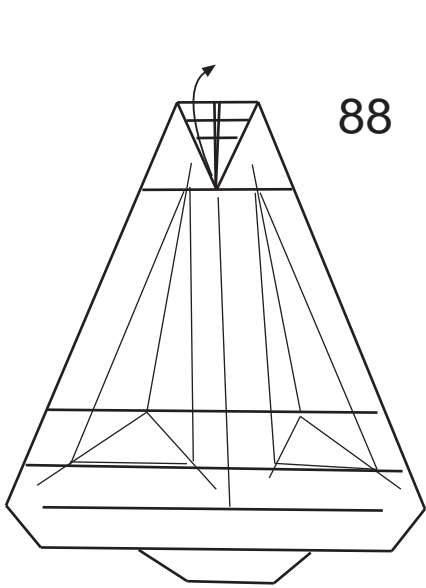

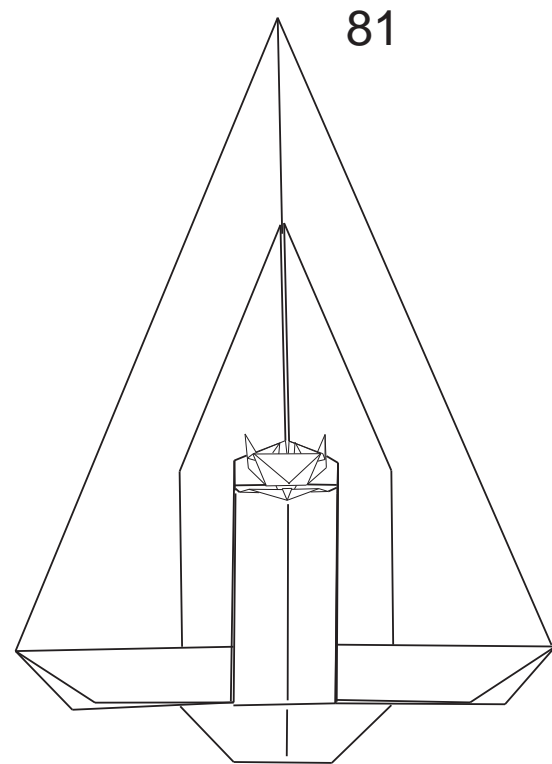
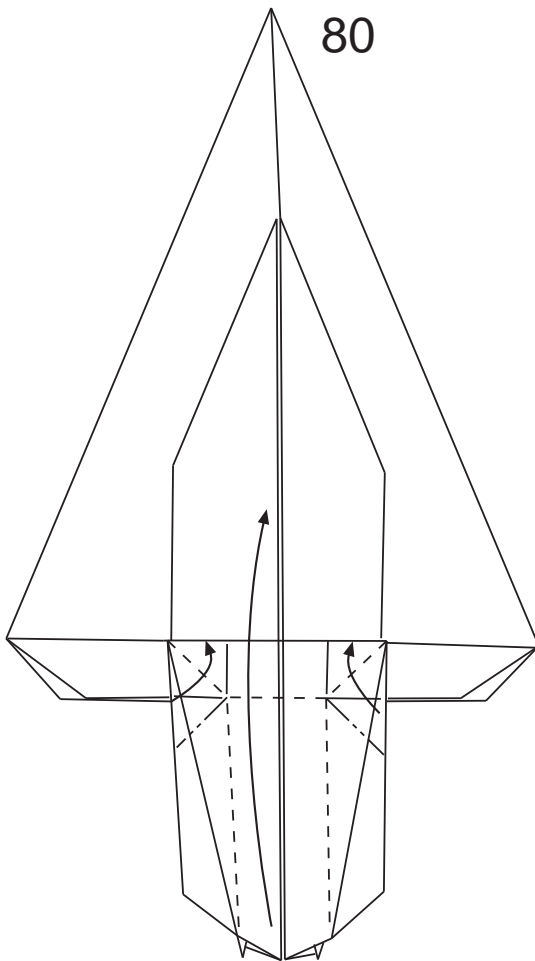
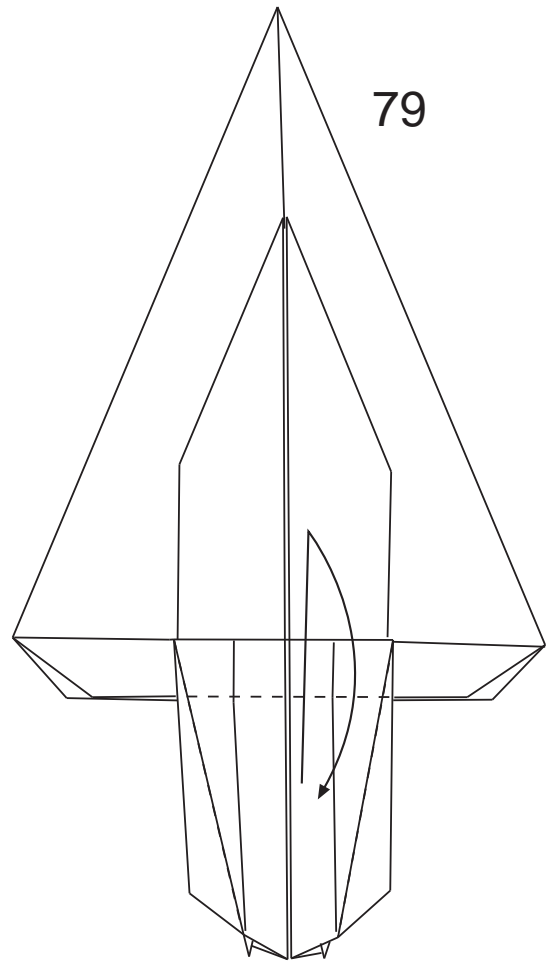
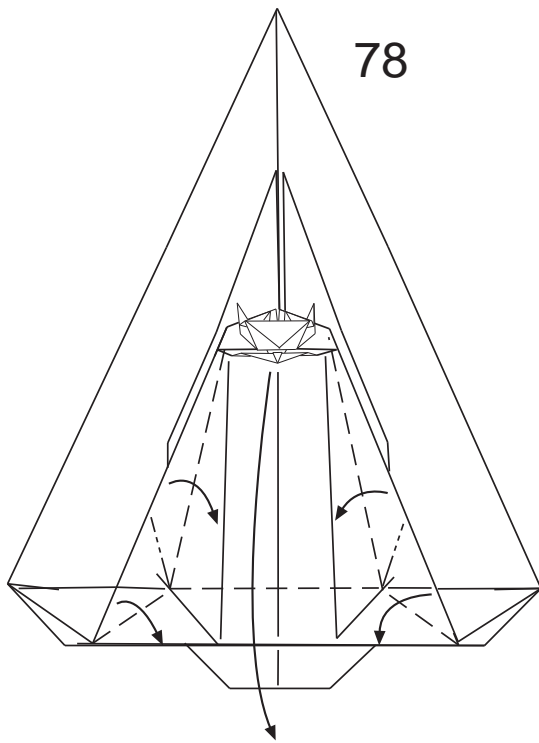

Dar la vuelta

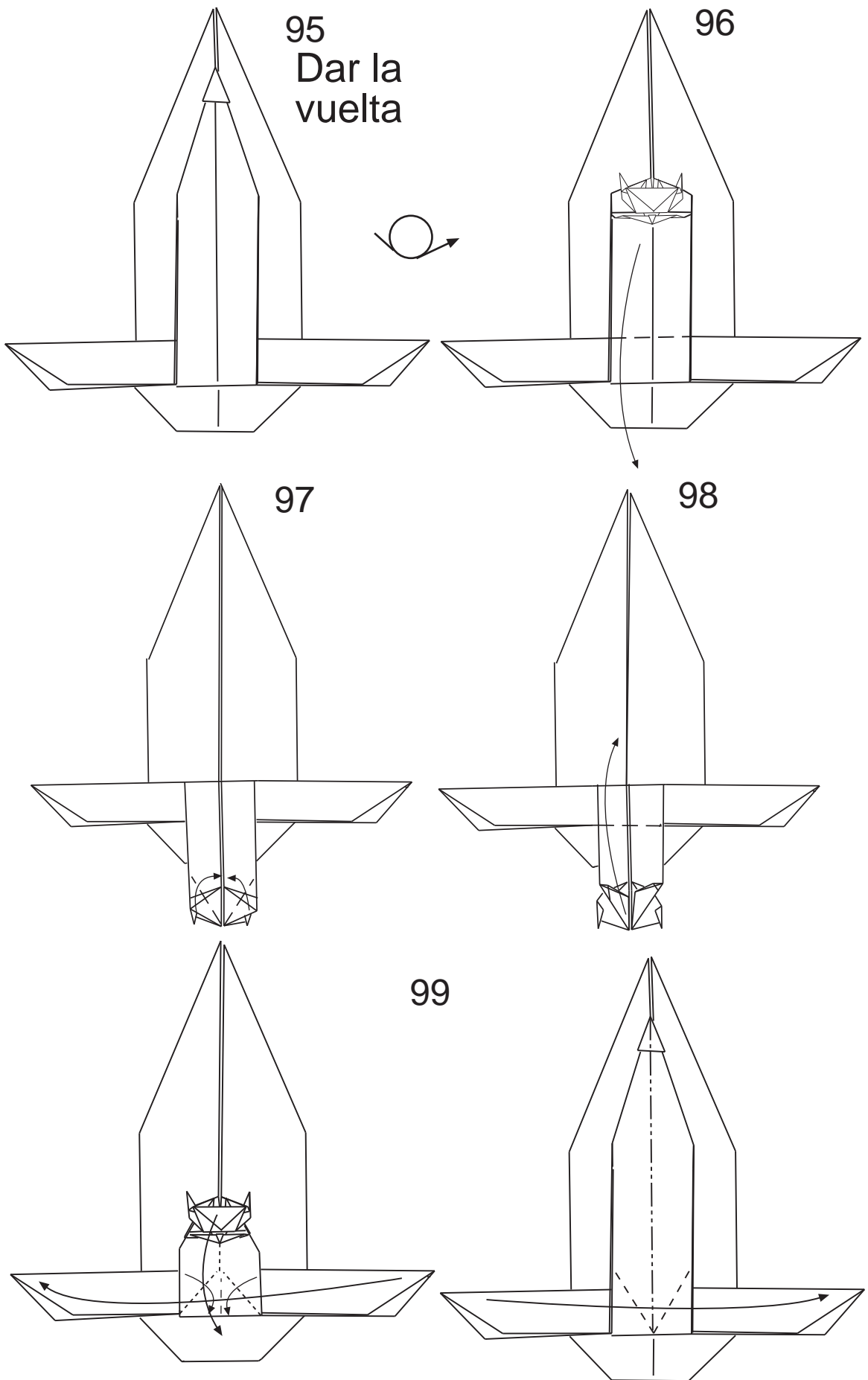

Los dos lados al mismo tiempo

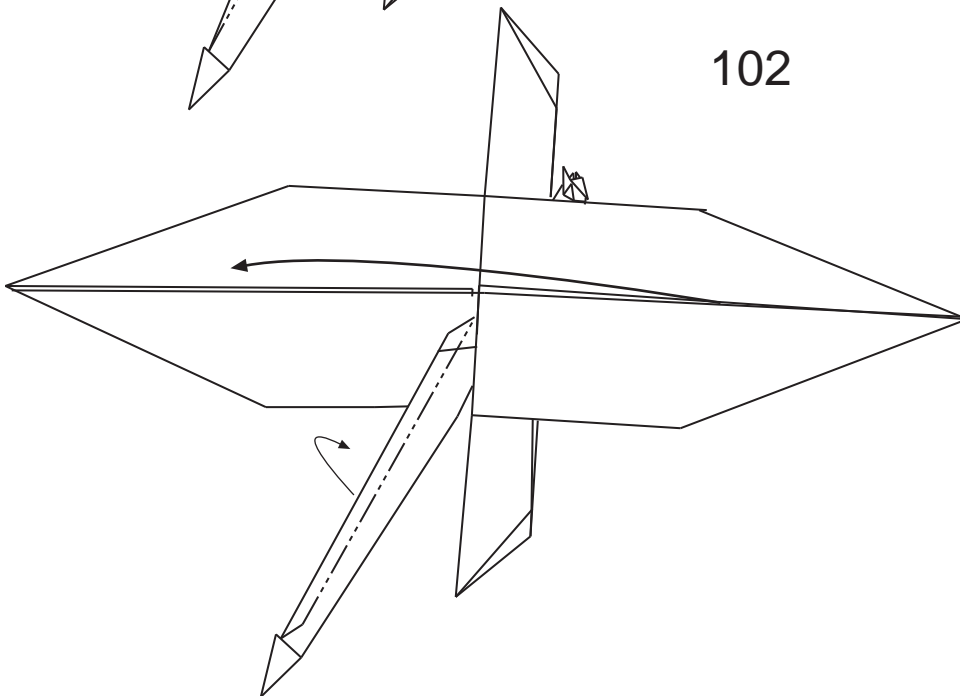
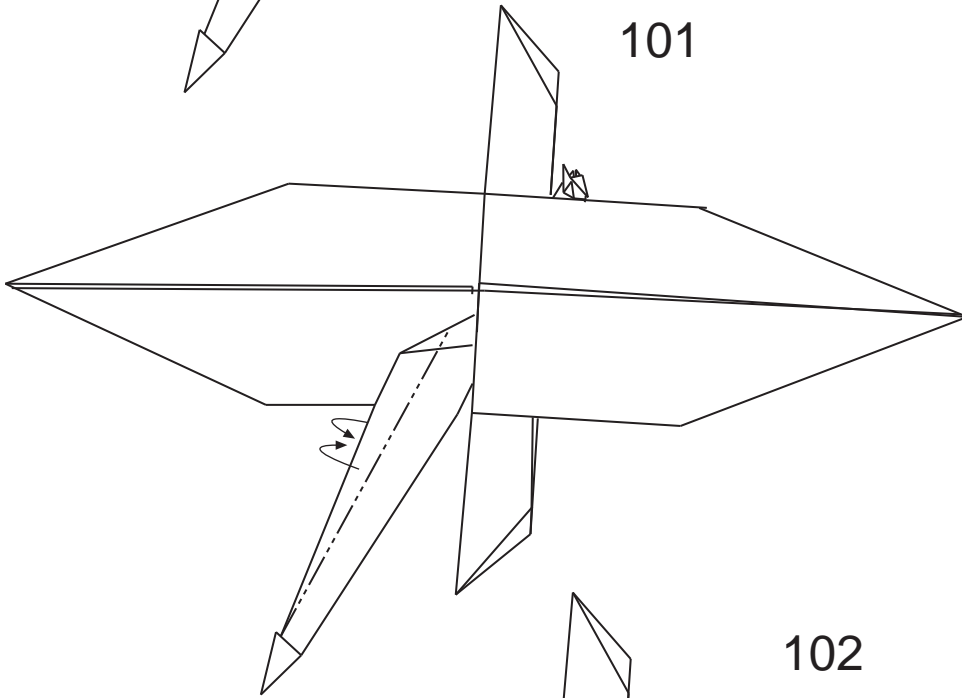
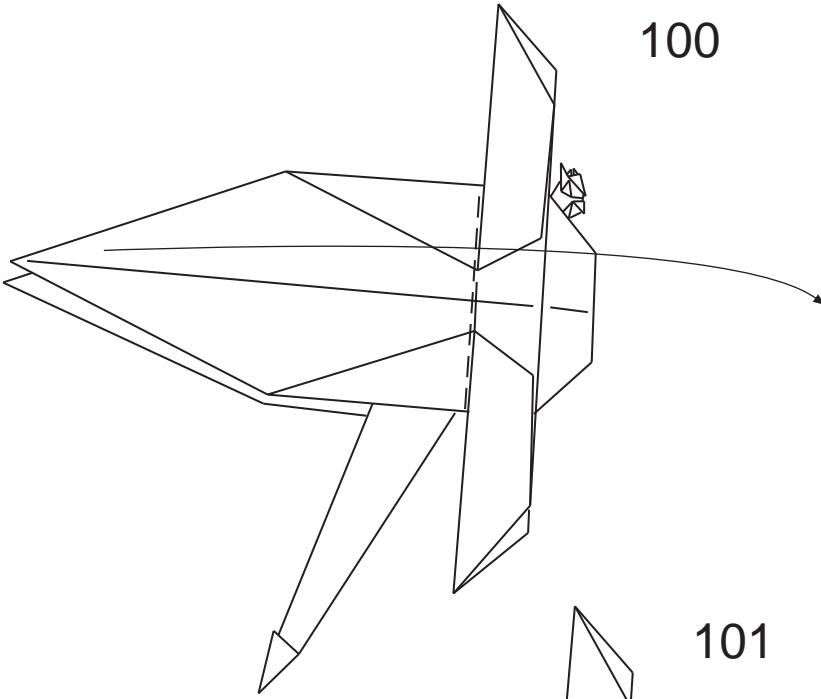

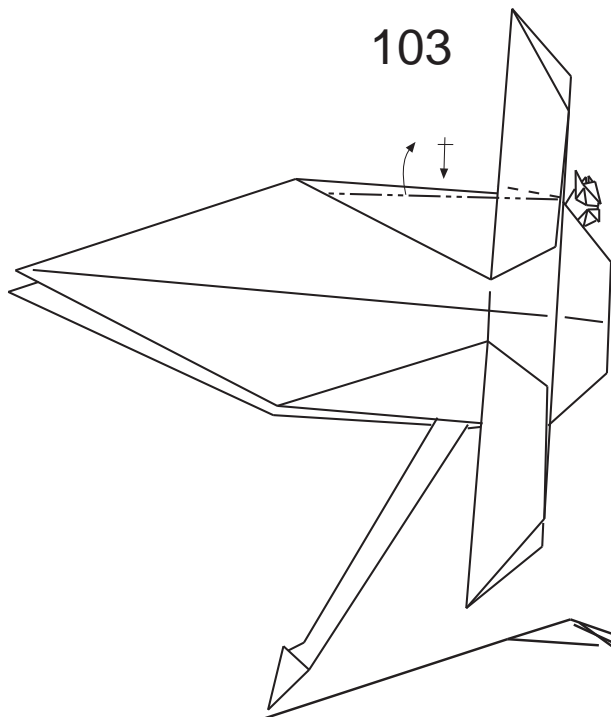

103

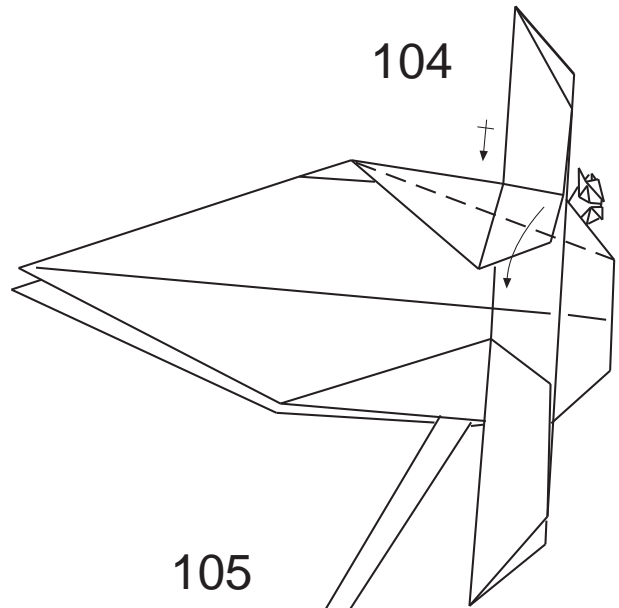

104

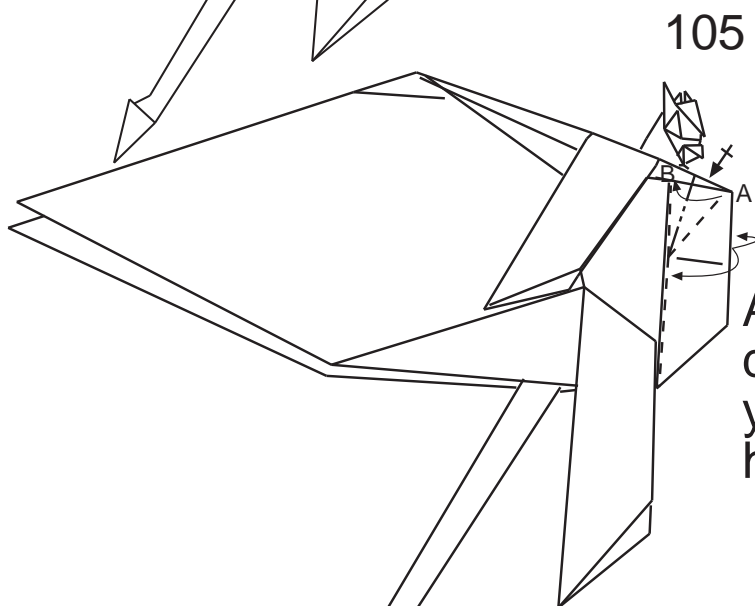

105

Abrir la parte
del pecho (A)
y unirla con los
hombros (B)

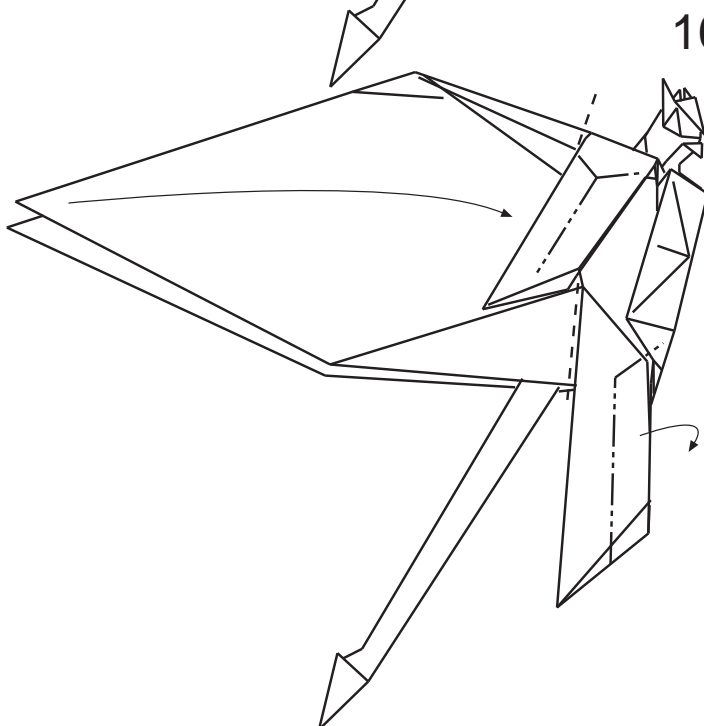

106

Plegar una
especie de
"oreja de conejo"
en los brazos y
en las piernas

107

Redondear
brazos y piernas

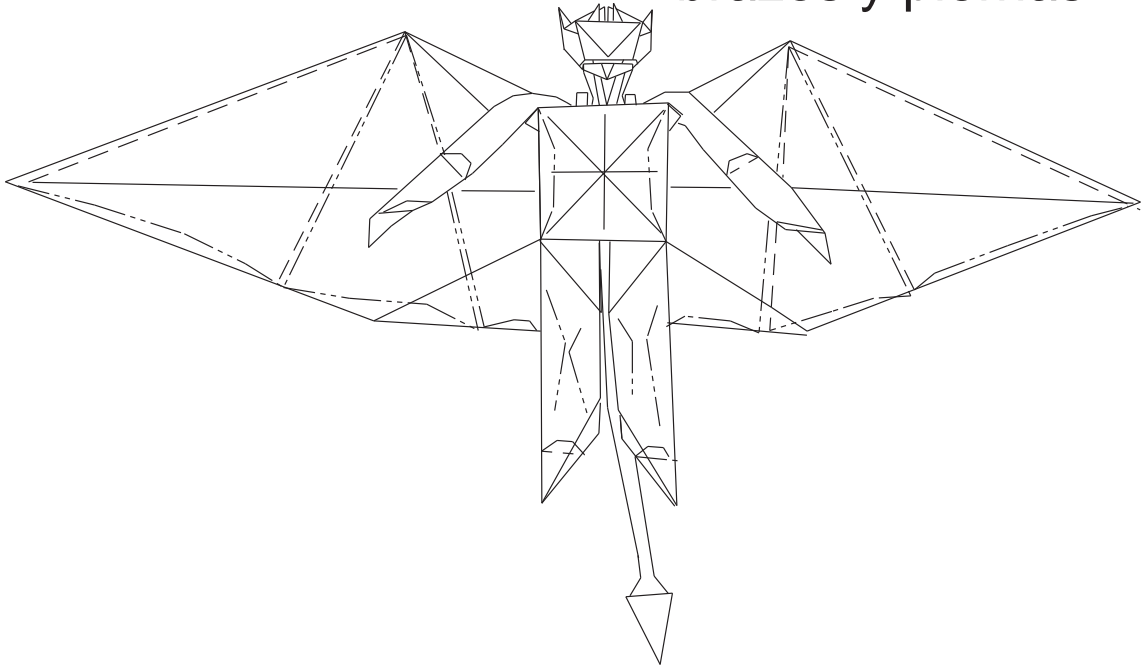

108

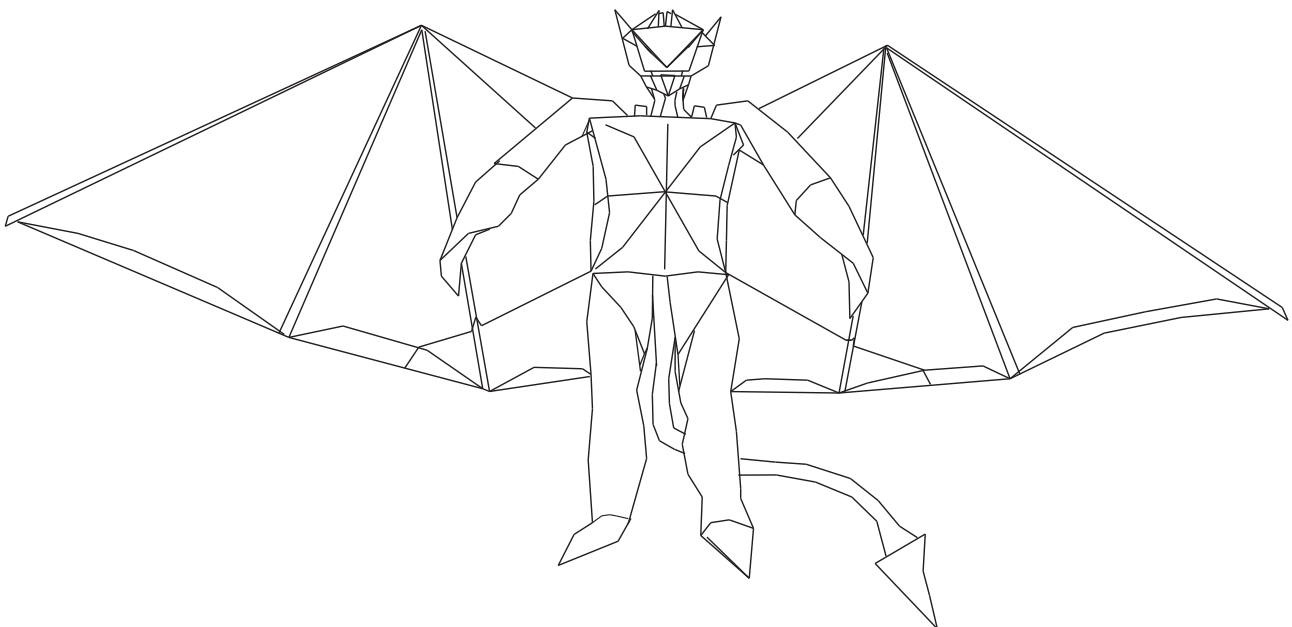

© Fernando Gilgado Gómez (Spain) 2002